



AN90026

LED drivers

Rev. 1.0 — 12 February 2021

application note

Document information

Information	Content
Keywords	LED driver, constant-current
Abstract	This application note presents the concept of constant-current LED drivers. The LED drivers referred in this application note with the suffix NCR are available from Nexperia.

1. Introduction

LEDs and LED applications are widely used across all market segment, having a significant impact on everyday life. Although high power LEDs need complex driver schemes and dedicated thermal concepts, the vast majority of applications use LEDs with currents far below 500 mA and can be driven by a very simple and robust driver solution using constant-current LED drivers which operate as a simple linear regulator. These are easy-to-use, reliable, cost efficient, and do not affect EMC.

In this application note the concept of constant-current LED drivers is presented, including how LED drivers can be easily integrated in the lighting concept for modern electronics with respect to power considerations, thermal concept, and packaging aspects.

Drivers referred to in this application note with the suffix NCR are available from Nexperia. They are used in automotive applications such as interior and exterior lighting (e.g. door handles, dashboard, number plate light, indicators and rear lights).

2. Concept of LED Drivers

Fig. 1 shows the internal topology and application schematic of three different LED drivers. Internally, such a driver consists of a BJT, two diodes, and two resistors. In Fig. 1 a) and Fig. 1 b) NPN BJTs operate as low-side drivers, while in Fig. 1 c) a PNP BJT is used to operate as high-side driver. One of the resistors defines the minimum output current and the other provides the bias voltage and plays an important role for the enable characteristic. Both the low-side drivers and the high-side driver have an enable pin. Low-side drivers need a specific potential to be enabled.

NCRx20x series drivers require a voltage in the range of the supply voltage to enable them, as shown in Fig. 1 a). The NCRx21x driver can be enabled at a much lower voltage of 3.3 V as indicated in Fig. 1 b). This part draws a current of about 1 - 2 mA at the enable pin so it can easily be driven by the output pin of a microcontroller or a logic device as indicated in Fig. 1 b). This provides convenient control of the LED's brightness by using a PWM output from a controller. The high-side constant-current driver has an enable pin which is connected to ground, thus the LED, can be turned off by disconnecting this pin. In practice, this is performed using a resistor-equipped transistor (RET), as illustrated in Fig. 1 c), or a MOSFET.

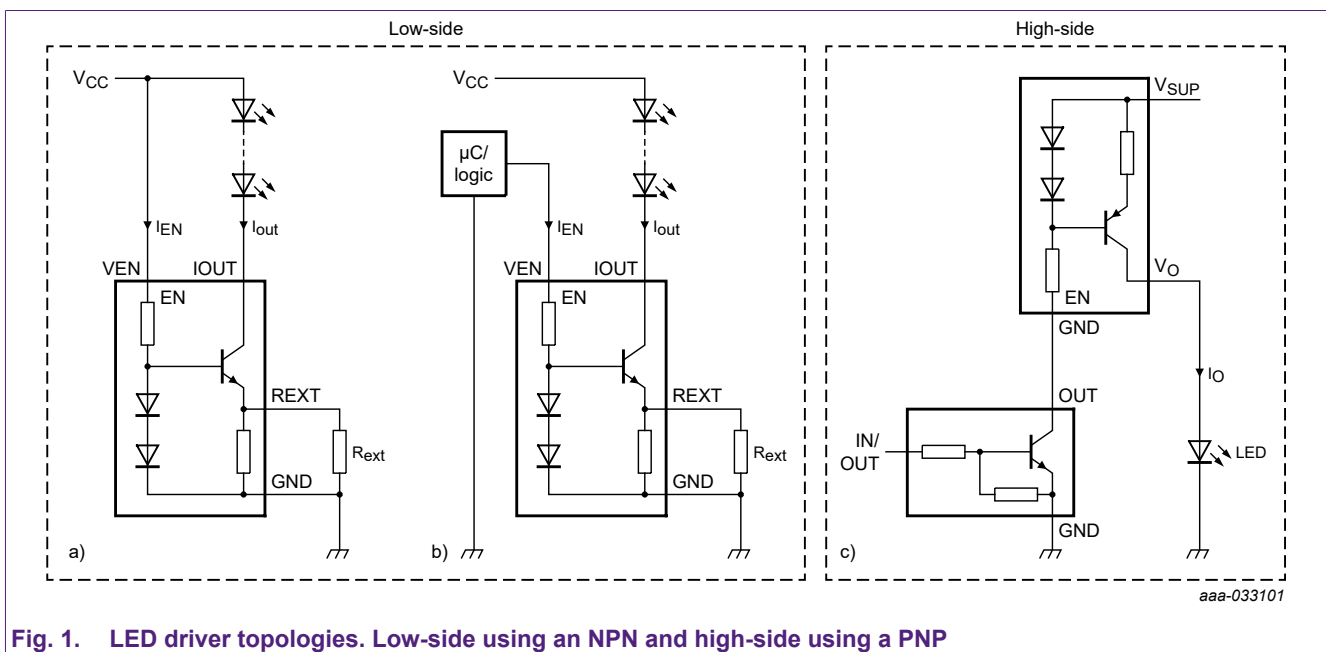

Fig. 1. LED driver topologies. Low-side using an NPN and high-side using a PNP

3. Electrical performance

The output current of constant-current LED drivers is adjustable by an external resistor R_{ext} . Some types are tuned to commonly used fixed currents using an internal resistor. As they do not feature an external resistor, they are available in 3-pin packages. In applications where an external resistor can be connected, it will be in parallel to the internal resistor, thereby lowering the effective resistance. The low-side constant-current drivers (NCRx2xx) using an NPN transistor have an internal resistor of 95 Ω . An analysis of the measurement curves provides the following formula which enables the relationship between external resistor and output current for a given $V_{EN} = 3.3$ V.

$$I_{out} \approx 0.5 \text{ mA} \cdot \left(\frac{R_{ext}}{\Omega}\right)^{-0.75}, \quad R_{ext} \approx 1 \text{ } \Omega \cdot \left(\frac{I_{out}}{0.5 \text{ mA}}\right)^{-1.33} \quad (1)$$

It should be mentioned that these formulas are derived by fitting measured data. They are not valid for values of V_{EN} other than 3.3 V. In those cases the formula should be adapted again using a curve fitting procedure.

The value of R_{ext} should not be too low to avoid excessive output current and hence damage of the LED driver. In case the external resistor is smaller than the internal resistor, most of the current will flow through the external resistor. Given a specific current target, the value of the resistor, based on [Eq \(1\)](#), can be chosen from [Table 1](#).

Table 1. LED current for a given resistor values (E24 series, 5%) calculated using Eq (1)

R_{ext} (Ω)	I_{out} (A)	R_{ext} (Ω)	I_{out} (A)
1,000	0.50	4,300	0.167
1,100	0.466	4,700	0.157
1,300	0.411	5,100	0.154
1,500	0.369	5,600	0.137
1,600	0.351	6,200	0.127
1,800	0.322	6,800	0.119
2,000	0.279	7,500	0.110
2,200	0.277	8,200	0.103
2,400	0.259	9,100	0.095
2,700	0.237	10,000	0.089
3,000	0.219	11,000	0.083
3,300	0.204	11,100	0.082
3,600	0.191	11,300	0.081
3,900	0.180		

Based on the tolerance of the E24 series of 5% the tolerance of the output current will be $\leq 3.8\%$.

It is important to note that the overall tolerance of the of the LED driver is not only dependent on the tolerance of R_{ext} but also on the internal tolerances of the device (e.g., internal resistors h_{FE}). Those internal tolerances are always present and contribute to an overall tolerance of the LED driver.

It should be mentioned that per definition the concept of constant-current LED drivers introduces a current drift depending on the temperature. In practice, this current drift is below $-0.3\%/K$ which would lead to a 6% current drift for a considerable large temperature drift of e.g., 20 °C. Typically, such temperature drifts happen very slowly and hence will not be very noticeable to the human eye.

In addition, the output current drift depends on supply voltage. This is typically $0.8\%/V$. In practice, when the LED driver is placed behind a buck or boost stage there is no relevant voltage change and hence no significant current drift is expected. When the LED driver is powered by the battery voltage and having a typical variation of the battery voltage between 11 and 16 V, the resulting current drift will be maximum 4%.

The dimming capability of the LED drivers (NCR321Z, NCR4x1Z) can be assumed to be linear, which means that the mean of the output current is linearly dependent on the duty cycle. This can be assumed for all typical dimming frequencies up to several kHz. However, the maximum recommended dimming frequency should maximum 10 kHz. Even for frequencies above the recommended 10 kHz, this linear relationship is maintained. However, due to higher harmonics, a switching frequency below 10 kHz should be preferred to stay compliant with the EMC requirements.

The minimum voltage drop across a constant-current driver is about 1.4 V. Below this voltage, linear regulation does not work properly. Above it, the voltage drop across the constant-current driver dynamically adjusts to enforce the desired output current. In low- and high-side configurations, the output voltage is always calculated as $V_{out} = V_{CC} - V_{LED}$ with V_{LED} as the voltage at the LEDs and V_{CC} as the supply voltage. Constant-current LED drivers are used when the brightness of an LED should be independent of the supply voltage to some degree. For example, the 12 V power supply in a car fluctuates between 11 V and 15 V during regular operation. If the desired drive current and the voltage drop across the LEDs are known, the minimum possible supply voltage can be calculated by adding the voltage drop across the driver plus the voltage at the LEDs. The maximum allowed voltage is governed by the maximum-permitted voltage drop across the driver V_{out} or the total power dissipation which can be estimated by $P_{tot} \approx V_{out} \times I_{out}$. Hence, the allowed operating range, if data sheet limits are not exceeded, can be specified as:

$$V_{LED} + 1.4 V < V_{CC} < V_{LED} + \frac{P_{tot}}{I_{out}} \quad (2)$$

Constant-current drivers in the SOT457 package usually have $P_{tot} = 0.75 W$. For an output current of 50 mA, this relates to a margin of 15 V. Newly released devices in a SOT223 package from Nexperia have an increased P_{tot} of 1.25 W which increases the voltage margin to 25 V.

Additionally, the voltage margin can be increased by reducing the output current. Placing two or more constant-current drivers in parallel, as illustrated in Fig. 2, effectively doubles the current. Using this method, current exceeding the capability of a single driver can be driven, or a smaller current per driver can be used to increase the voltage margin. Using two constant-current, SOT223-packaged drivers with a drive capability of 250 mA, enables the circuit to drive 500 mA LEDs with a voltage margin of 5 V. When driving constant-current drivers in parallel, the accuracy of the external resistors is the most important factor for the symmetry of the output currents of the individual drivers. Fig. 3 illustrates the voltage margins depending on the output current for single and parallel drivers in SOT457, SOT223, and DFN2020D-6 packages using $V = P_{tot}/I_{out}$.

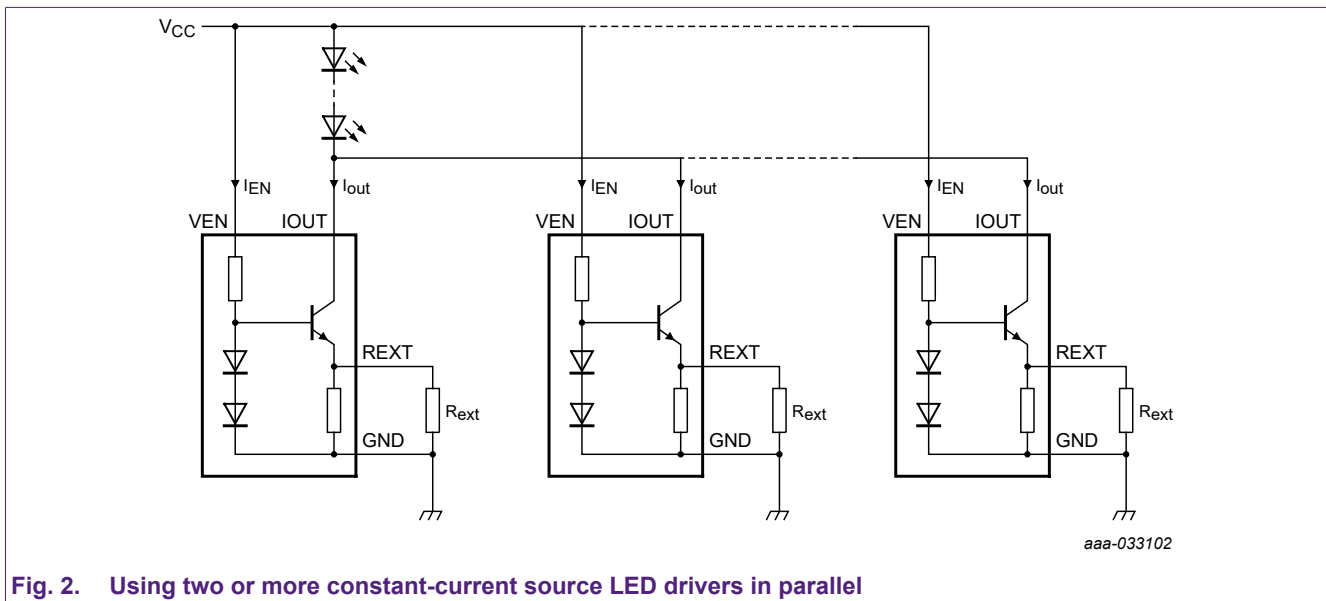
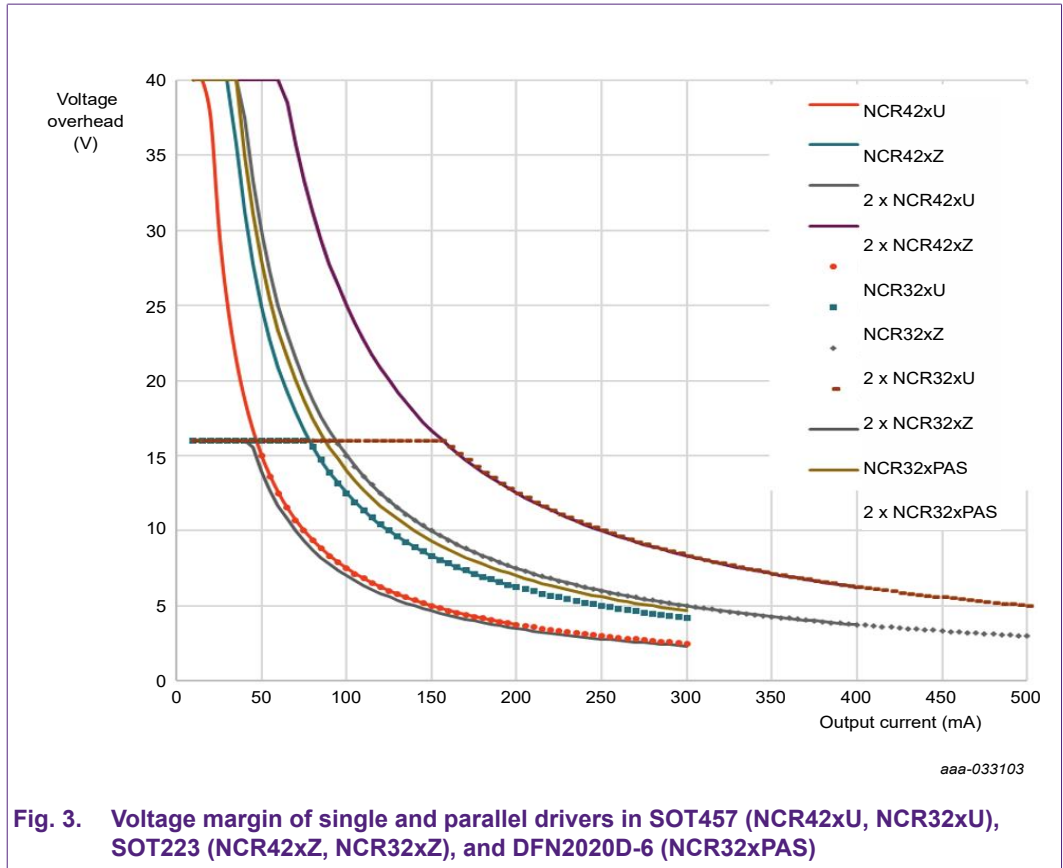
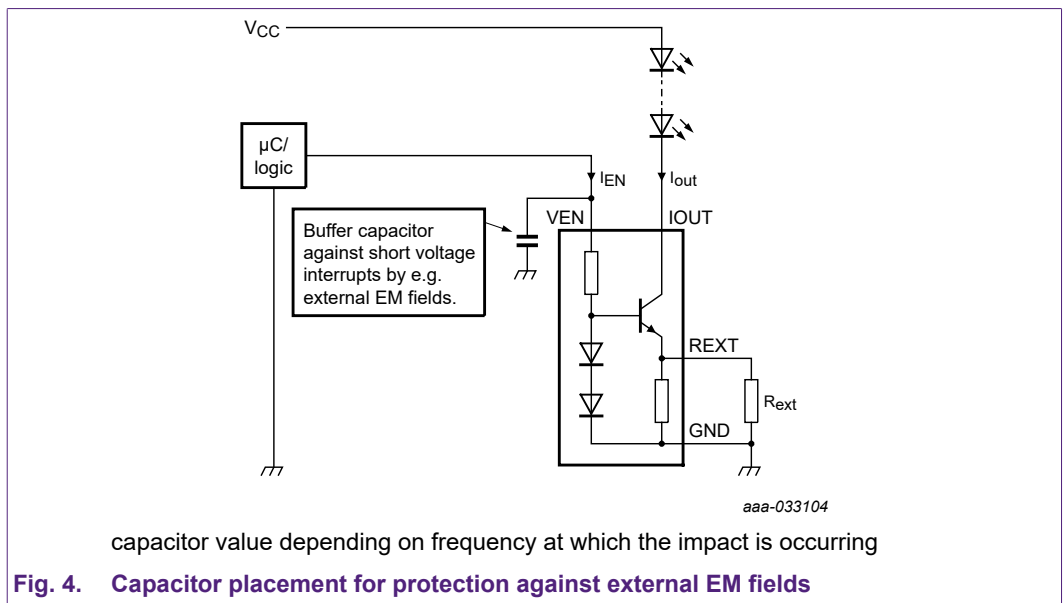

Fig. 2. Using two or more constant-current source LED drivers in parallel



4. EMC Behavior

In DC applications, where the EN pin is driven by a DC voltage, there is typically no emission spectrum expected. However, in the presence of external electromagnetic (EM) waves the enable pin can be disturbed which can then lead to significant deviation of the LED current. To prevent this, a capacitor placed as close as possible to the enable pin can be used, see Fig. 4. The value of this capacitor can be chosen according to the frequency where the disturbance is expected, see Fig. 5.



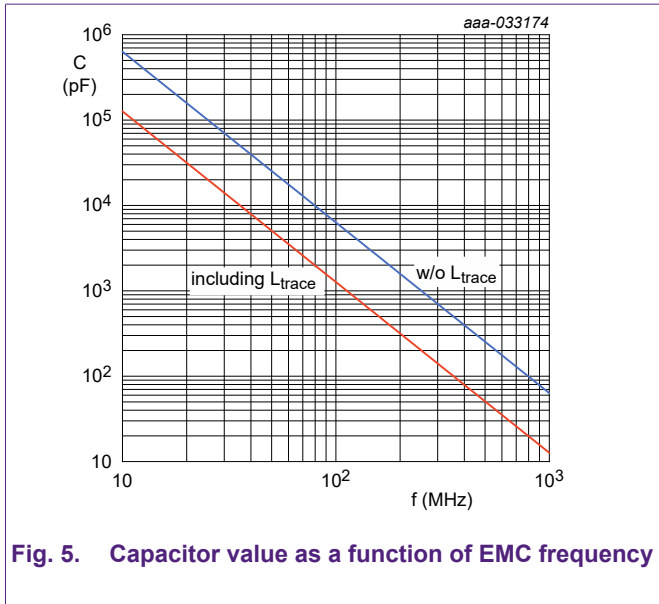

Fig. 5. Capacitor value as a function of EMC frequency

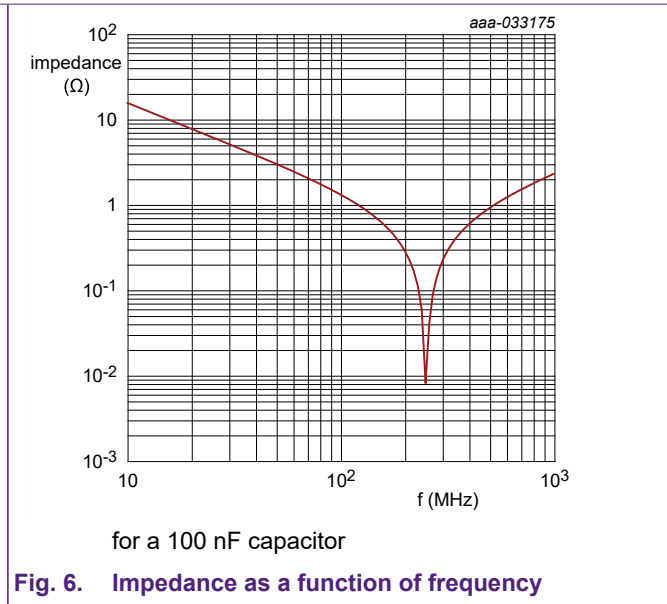

Fig. 6. Impedance as a function of frequency for a 100 nF capacitor

In Fig. 4 the placement of the capacitor is indicated in the schematic and values for the capacitor are calculated using:

$$C = \frac{I}{(2 \cdot \pi \cdot f)^2 \cdot ESL} \tag{3}$$

400 pH is used as a typical value of equivalent series inductance (ESL) for an 0603 capacitor. In some cases, it is not possible to connect the capacitor directly to the ground plane, so additional traces and/or vias are used. All traces and vias add a significant parasitic inductance (~1 nH per mm trace or via) to the circuit which impacts the effective operating frequency of the capacitor. To consider this, the capacitance values are given for a parasitic inductance of $L_{\text{trace}} = 2$ nH. It should be mentioned that when adding this capacitor, the output of your logic should be checked to be able to charge and discharge the capacitor in the required time, otherwise a series resistor should be added.

For PWM application where the EN pin is driven by a digital signal with a certain frequency, the recommendation is for the switching frequency not to exceed a switching frequency of 10 kHz. However, having a rectangular signal means that higher harmonics should be also considered. As shown in Fig. 7, the first 10 Fourier amplitudes for a fundamental 10 kHz. Only the 10th harmonic appears close to the 125 kHz band.

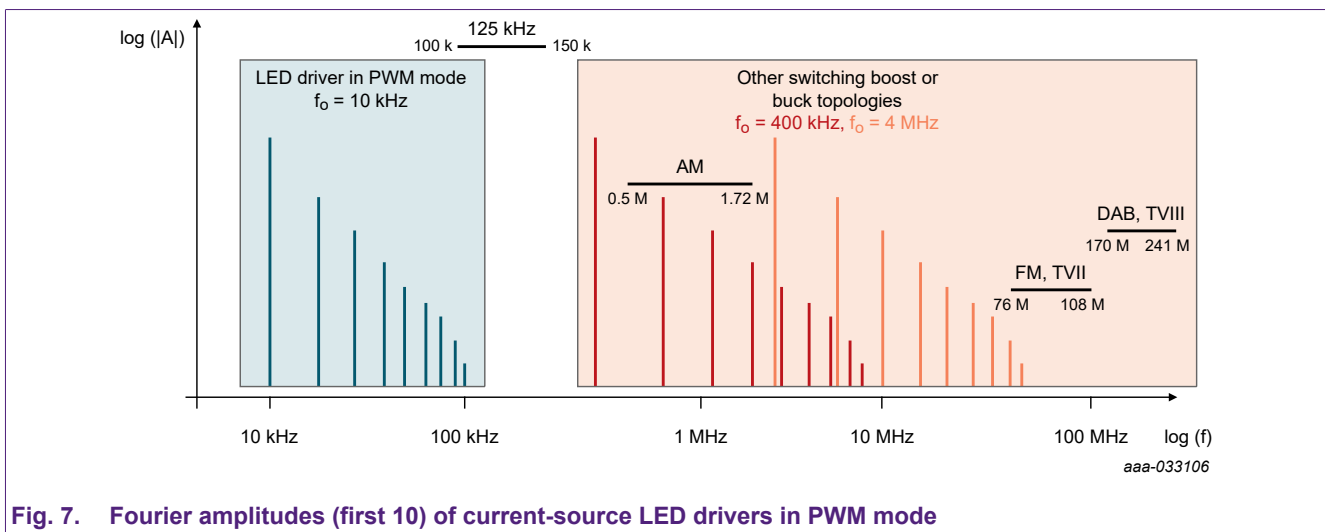

Fig. 7. Fourier amplitudes (first 10) of current-source LED drivers in PWM mode





The limits of this band are 41dB ($\mu\text{V}/\text{m}$) which is much higher compared to the 10th harmonics of the LED Driver. In comparison, other LED driving solutions such as switched boost or buck solution are shown. Their typically switching frequency is in the range of several hundred kHz to a few MHz. From the emission point of view, this can be very critical because several very important frequency bands such as the AM radio which is ranging from 0.5 to 1.73 MHz, can be violated. Also, higher bands such as FM and DAB which are beyond 100 MHz can be impacted heavily by higher harmonics, especially in presents of internal resonances.

Compared to conventional boost or buck topologies, the current source drivers show a significantly better EMC performance even in the PWM mode.

5. Thermal performance

The LED drivers come in five different packages. From the perspective of the power dissipation there are several differences between the packages. [Table 2](#) shows the comparison of electrical and thermal parameters for the available packages. As can be seen, the SOT23 is suitable for low-current and low-power application requiring also small area on the PCB. The SOT223 as the largest package shown here, is well suited for up to 1250 mW. It should be mentioned that also DFN packages have a very solid thermal performance with a maximum current up to 300 mA and power up to 700 mW.

Table 2. Thermal parameter (maximum values) for the packages available for the LED drivers

	SOT23	SOT223	SOT457	SOT353	DFN2020D-6
					
P_{tot} (mW) [1]	400	1,250	750	335	700
I_{max} (mA)	20	250	250	50	300
$R_{\text{th(j-a)}}$ (K/W) [1]	465	100	165	317	236
$R_{\text{th(j-a)}}$ (K/W) [2]	312	70	115	-	170

[1] Device mounted on an FR4 PCB, 4-layer copper, tin-plated and standard footprint.

[2] Device mounted on an FR4 PCB, 4-layer copper, tin-plated mounting pad for collector 1 cm².

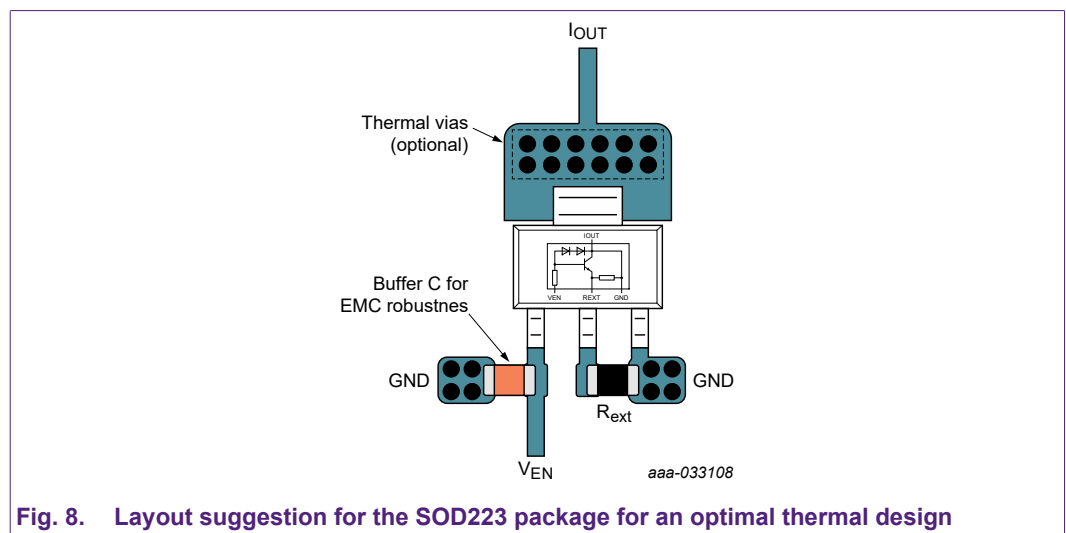

Fig. 8. Layout suggestion for the SOD223 package for an optimal thermal design

For the I_{OUT} pin it is recommended to use a sufficient pad size, with enough thermal vias to improve the heat sinking. A similar approach can be used for other packages from [Table 2](#).

6. Revision history

Table 3. Revision history

Revision number	Date	Description
1.0	2021-02-12	Initial version.

7. Legal information

Definitions

Draft — The document is a draft version only. The content is still under internal review and subject to formal approval, which may result in modifications or additions. Nexperia does not give any representations or warranties as to the accuracy or completeness of information included herein and shall have no liability for the consequences of use of such information.

Disclaimers

Limited warranty and liability — Information in this document is believed to be accurate and reliable. However, Nexperia does not give any representations or warranties, expressed or implied, as to the accuracy or completeness of such information and shall have no liability for the consequences of use of such information. Nexperia takes no responsibility for the content in this document if provided by an information source outside of Nexperia.

In no event shall Nexperia be liable for any indirect, incidental, punitive, special or consequential damages (including - without limitation - lost profits, lost savings, business interruption, costs related to the removal or replacement of any products or rework charges) whether or not such damages are based on tort (including negligence), warranty, breach of contract or any other legal theory.

Notwithstanding any damages that customer might incur for any reason whatsoever, Nexperia's aggregate and cumulative liability towards customer for the products described herein shall be limited in accordance with the Terms and conditions of commercial sale of Nexperia.

Right to make changes — Nexperia reserves the right to make changes to information published in this document, including without limitation specifications and product descriptions, at any time and without notice. This document supersedes and replaces all information supplied prior to the publication hereof.

Suitability for use — Nexperia products are not designed, authorized or warranted to be suitable for use in life support, life-critical or safety-critical systems or equipment, nor in applications where failure or malfunction of an Nexperia product can reasonably be expected to result in personal injury, death or severe property or environmental damage. Nexperia and its suppliers accept no liability for inclusion and/or use of Nexperia products in such equipment or applications and therefore such inclusion and/or use is at the customer's own risk.

Applications — Applications that are described herein for any of these products are for illustrative purposes only. Nexperia makes no representation or warranty that such applications will be suitable for the specified use without further testing or modification.

Customers are responsible for the design and operation of their applications and products using Nexperia products, and Nexperia accepts no liability for any assistance with applications or customer product design. It is customer's sole responsibility to determine whether the Nexperia product is suitable and fit for the customer's applications and products planned, as well as for the planned application and use of customer's third party customer(s). Customers should provide appropriate design and operating safeguards to minimize the risks associated with their applications and products.

Nexperia does not accept any liability related to any default, damage, costs or problem which is based on any weakness or default in the customer's applications or products, or the application or use by customer's third party customer(s). Customer is responsible for doing all necessary testing for the customer's applications and products using Nexperia products in order to avoid a default of the applications and the products or of the application or use by customer's third party customer(s). Nexperia does not accept any liability in this respect.

Export control — This document as well as the item(s) described herein may be subject to export control regulations. Export might require a prior authorization from competent authorities.

Translations — A non-English (translated) version of a document is for reference only. The English version shall prevail in case of any discrepancy between the translated and English versions.

Trademarks

Notice: All referenced brands, product names, service names and trademarks are the property of their respective owners.

List of Tables

Table 1. LED current for a given resistor values (E24 series, 5%) calculated using Eq (1)..... 3

Table 2. Thermal parameter (maximum values) for the packages available for the LED drivers..... 7

Table 3. Revision history.....8

List of Figures

Fig. 1. LED driver topologies. Low-side using an NPN and high-side using a PNP.....	2
Fig. 2. Using two or more constant-current source LED drivers in parallel.....	4
Fig. 3. Voltage margin of single and parallel drivers in SOT457 (NCR42xU, NCR32xU), SOT223 (NCR42xZ, NCR32xZ), and DFN2020D-6 (NCR32xPAS).....	5
Fig. 4. Capacitor placement for protection against external EM fields.....	5
Fig. 5. Capacitor value as a function of EMC frequency.....	6
Fig. 6. Impedance as a function of frequency.....	6
Fig. 7. Fourier amplitudes (first 10) of current-source LED drivers in PWM mode.....	6
Fig. 8. Layout suggestion for the SOD223 package for an optimal thermal design.....	7

Contents

1. Introduction.....	2
2. Concept of LED Drivers.....	2
3. Electrical performance.....	3
4. EMC Behavior.....	5
5. Thermal performance.....	7
6. Revision history.....	8
7. Legal information.....	9

© Nexperia B.V. 2021. All rights reserved

For more information, please visit: <http://www.nexperia.com>
For sales office addresses, please send an email to: salesaddresses@nexperia.com
Date of release: 12 February 2021
